

## AUTOMATIC PNEUMATIC SAMPLER

### MODEL D

- **SUITABLE FOR POWDERS AND GRANULES**
- **SAMPLE CATCHMENT FROM HOPPERS, CHUTES, ETC**
- **NO PRODUCT DEGRADATION**
- **SIMPLE AIRTIGHT, DUST-TIGHT CONSTRUCTION**

This pneumatically operated sampler is designed to provide a representative sample of powders and granules from hoppers, chutes, etc.

The aluminium alloy body and spool are electroless nickel plated for abrasion and corrosion resistance and, with PTFE seals, permits the Sampler to be used with a wide range of materials.

Operation is by a pneumatic VDMA cylinder and is controlled by a 5/2 single solenoid valve fitted as standard.

The spool extends into the product to be sampled by means of the pneumatic cylinder, the spool fills with product (approx. 0.2 litres volume) and retracts allowing the product to fall by gravity to the collection point.

By using a double seal arrangement, the sample catchment area is always fully isolated from the collection point thus ensuring dust-tight and airtight operation.

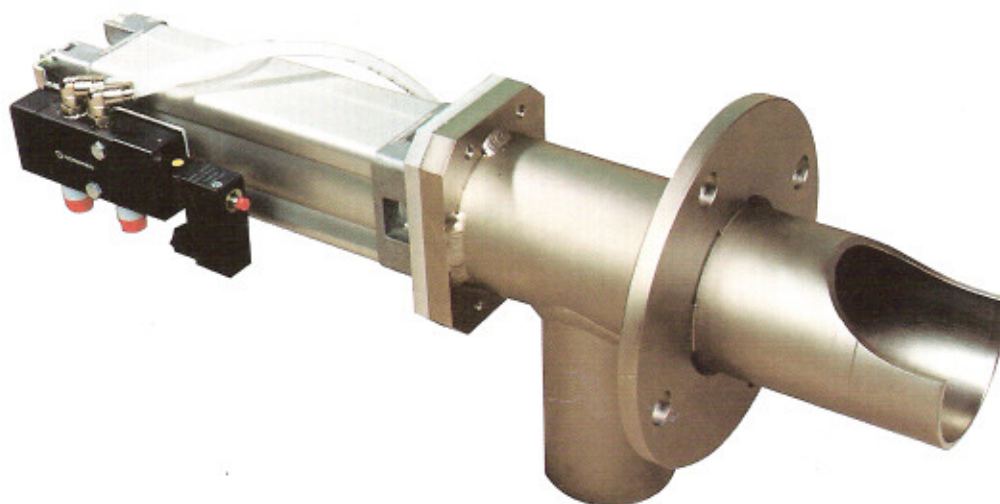

**Britton**  
POWDER CONTROL

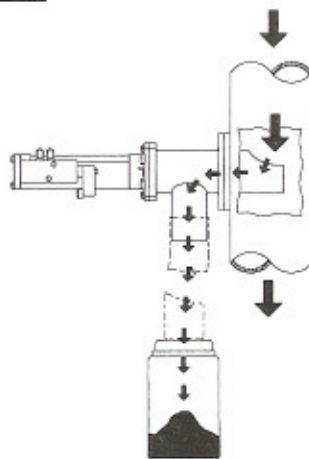
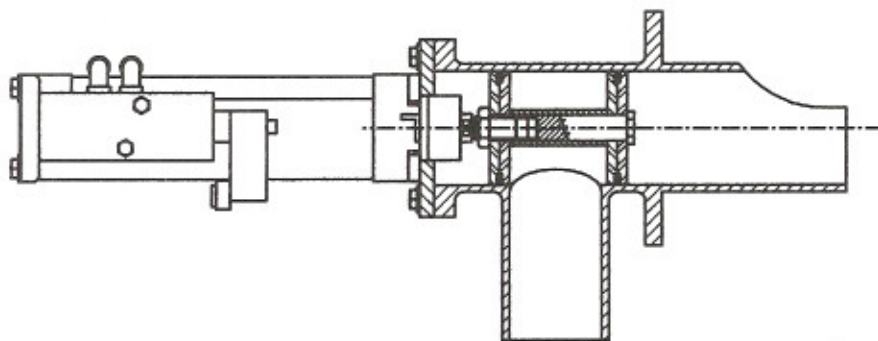
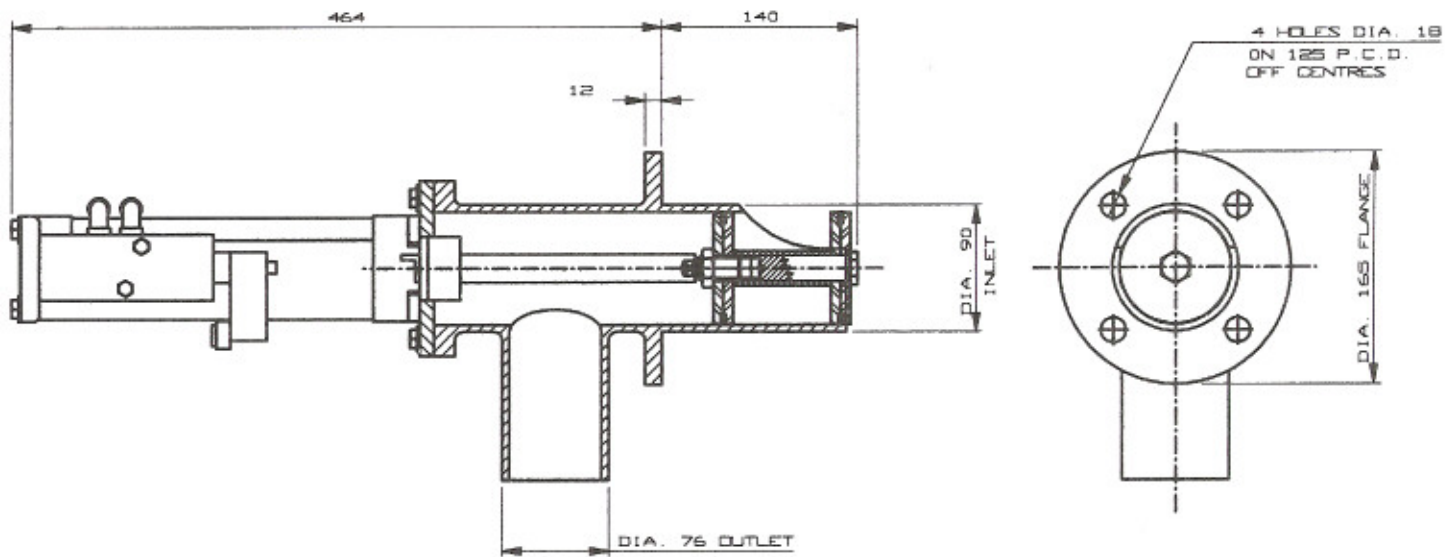

MOUNTING POSITION

**OPTIONS:**

- Fully adjustable electrical sequence control unit
- Fully adjustable pneumatically operated control unit
- Electrical indication of sampler position
- Smooth bore flexible hose and sample container with wall mounting bracket

We are continually developing our products and accordingly we reserve the right to change specifications and dimensions without prior notice.



BRITTON VALVES LTD · KYNOCHS · BIDEFORD  
DEVON · ENGLAND · EX39 4DT

TEL 01237 477465 · FAX 01237 421459