

# **Operating and Maintenance Instructions**

---

## **FABRICATED ROTARY VALVES**

---

### **Britton Procol Valves**

4 The Green Old Dalby Leicestershire LE14 3LL England  
Phone +44 (0) 1664 822 611 Fax: +44 (0) 1664 822 665

## **INDEX**

HEALTH & SAFETY NOTES

ROTARY VALVE GUARDING

GENERAL SPECIFICATION

INSTALLATION

INITIAL MAINTENANCE

GENERAL MAINTENANCE

ROTOR BLADE RENEWAL

FAULT FINDING

RECOMMENDED SPARES

## **GENERAL HEALTH & SAFETY NOTES**

Only qualified or approved personnel should undertake the installation, commissioning and maintenance of Procol Rotary Valves.

Health and Safety aspects cannot be over emphasised. The following notes highlight the major precautionary steps which must be adhered to.

In the interest of Health and Safety at Work it is essential that, before installation, all aspects relating to installation, mounting position, support and all other related matters should be thoroughly investigated. Technical details relating to this equipment are either shown in the relevant leaflets or are freely available on demand from our technical department. If further advice is required, do not hesitate to contact us.

### **CHECK LIST BEFORE RUNNING**

- 1      Observe fully all operating and safety instructions supplied with the Rotary Valve and geared motor.
- 2      Ensure that the valve inlet and outlet are protected by the feed and discharge ducting or other equipment so that it is impossible for operatives or maintenance personnel to insert fingers, hands or any part of their bodies into the valve. A guide to guarding Procol Rotary Valves is included in the next section of these notes.
- 3      Where the valve outlet is not connected to other equipment or ducting a mesh grille must be securely fastened to the exposed flange. The grille should be sufficiently small to prevent the insertion of fingers.
- 4      If the valve has body vent ports they will be fitted with threaded plugs. Do not remove these plugs from the valve and insert fingers - they will be amputated.
- 5      Always isolate and lock-off all the electrical power supply to the geared motor before attempting any maintenance or other work on the valve.



## **HEALTH & SAFETY NOTES**

### **ROTARY VALVE GUARDING**

Rotary Valves designed and manufactured by Britton Procol Valves are guarded to prevent access to all external rotating components. However the inlet and outlet of the valves must be guarded in situ to prevent anyone inserting hands, fingers etc into the rotating valve. This guarding cannot be incorporated into the assembly of the valve and is not supplied by Britton Procol Valves. It must therefore be provided by the installation contractor and fitted as a separate guard on site during plant assembly.

Normally in a closed system, equipment to which the Rotary Valve is attached will form an adequate guard to prevent access to the rotating rotor. This may be the incoming and outgoing chutes or the feed hopper and adjacent take away equipment ie screw conveyor.

Where the Rotary Valve is the final piece of equipment, and there is no chute to prevent access to the rotor, a mesh guard fitted onto the valve inlet or outlet flange is mandatory in order to comply with Health and Safety legislation. The mesh must be small enough to prevent the insertion of fingers into the valve and must be securely fastened to prevent easy removal.

Britton Procol Valves recommend that an interlock switch is fitted to the guard to prevent the valve running if the guard is removed for maintenance.

Britton Procol Valves have designed mesh guards suitable for the outlet of all their Rotary Valves. These guards may be purchased direct or customers may elect to design and manufacture their own.

The following sketches indicate some typical applications which require guards fitting to the inlets and outlets of Rotary Valves. They do not form, and should not be used as, a comprehensive guide to the guarding of Rotary Valves and each application must be considered separately. Our technical department may be consulted for advice if required.

**REMEMBER ROTARY VALVES BITE!!!**

**FINGERS AND HANDS WILL BE AMPUTATED IF  
THEY ARE INSERTED INTO A ROTATING VALVE.**

**INLET & OUTLET GUARDING IS MANDATORY**

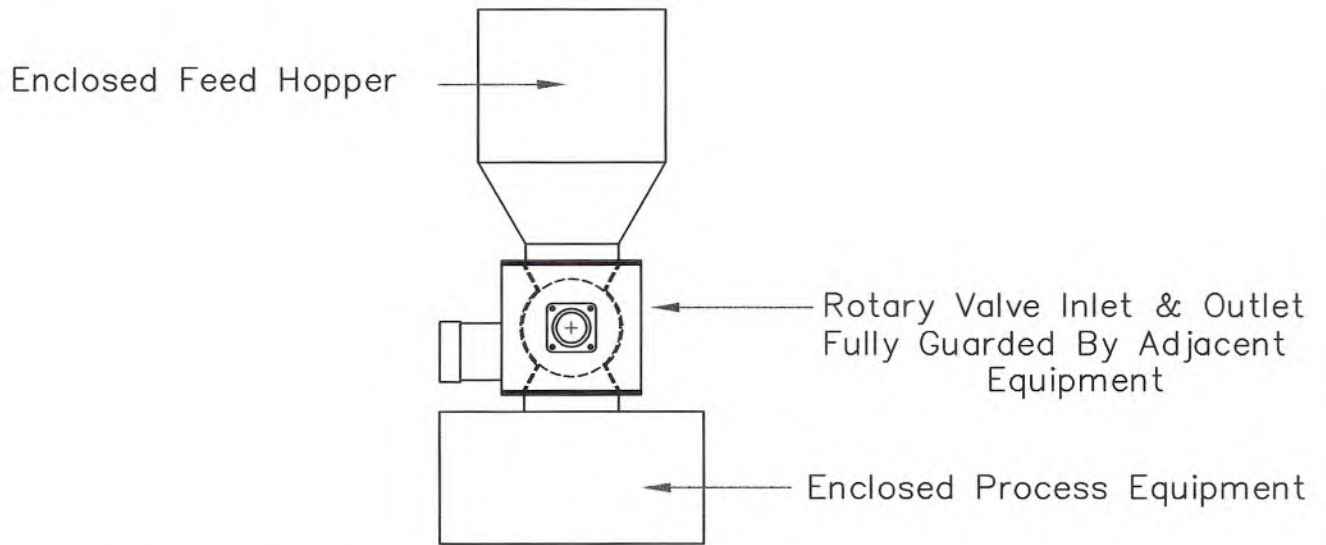

Enclosed System: – Valve Inlet And Outlet Fully Guarded By Adjacent Equipment

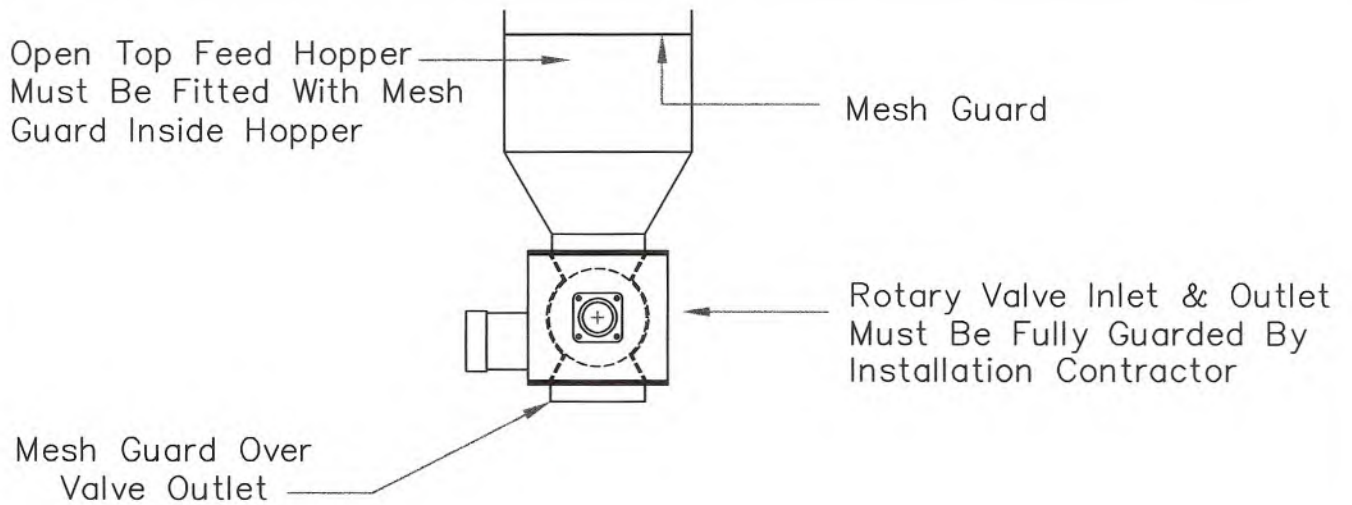

Open System: – Valve Inlet And Outlet Are Not Guarded By Adjacent Equipment  
ADDITIONAL GUARDS MUST BE FITTED

Britton Procol  
  
 VALVES

HEAD OFFICE: Kynochs Industrial Estate Bideford Devon EX39 4DT England Tel: +44 (0) 1237 477 465 Fax: +44 (0) 1237 421 459  
 SALES OFFICE: 10 Purbeck Drive West Bridgford Nottingham NG2 7UA England Tel: +44 (0) 1158 469 469 Fax: +44 (0) 1158 461 834

THE DOWSON GROUP

[www.dowsongroup.com](http://www.dowsongroup.com)

BRITTON PROCOL VALVES

DOWSON HANDLING

HELI-TEC

WRIGHTS



## ROTARY VALVE SPECIFICATION

Procol Rotary Valves are designed to metric standards and all fasteners or threads are metric.

- Body** Fabricated from 5mm thick carbon steel and ABRO 400 abrasion resistant plate. Square inlet and outlet
- Endplates** Fabricated from 6mm thick ABRO 400 abrasion resistant plate.
- Rotor** Fabricated mild steel 6 blade open rotor with reinforced natural rubber flexible blades cut to give a close clearance with the valve body.
- Bearings** None drive side: Sealed self lube deep groove ball bearing mounted in a cast iron flanged housing.
- Drive** Worm geared motor TEFC IP55 suitable for AC277/480-3-60 supply. The motor will incorporate thermistors and be suitable for use with an inverter speed controller.

**Paint Finish** Procol Sapphire Blue air drying gloss paint BS 4800 20D45.

All valves are Works tested before despatch and are ready for installation.

If the Rotary Valve is to be stored, it is important that machined surfaces and shafts are coated in a thin film of mineral oil to prevent the formation of rust.

The valves should be stored in a clean, dry environment.

The geared motor has been filled with lubricant in our works prior to despatch.

## **INSTALLATION**

The valve flanges are supplied flat and it is important, in order to prevent distortions or stresses within the valve body, that the mating flanges are also flat and level.

A soft gasket or mastic should be inserted between the valve and the mating flange. This will ensure a dust and weather-tight seal and will help to prevent valve body distortion.

Tighten the fixing bolts evenly and check that the rotor rotates freely.

Most geared motors are supplied grease packed or oil filled and do not require lubrication, however every unit must be checked and filled with the appropriate grade of oil or grease if required.

Before running the valve the approach equipment ie hopper, ducting, screw feeder etc should be thoroughly cleaned and free from foreign matter. Serious damage will be caused to the Rotary Valve by weld spatter, nuts, bolts, pieces of wood etc if they are allowed to enter it.

### **ATEX Regulations**

When Rotary Valves are installed in potentially explosive atmospheres they will be certified for use in Zone 21 or Zone 22 areas. The operator must ensure that the valves are adequately earthed to prevent static discharges caused by non-conductive media.

### **Start-up Procedure**

#### **Check the following:**

- 1 All safety equipment, i.e. guards, cut-out flaps and inspection flaps and lids are closed, that the valve is empty.
- 2 Connect the electrical power to the motor. This work must only be carried out by a qualified electrical engineer following the instructions provided with the motor.
- 3 Where the valve is part of a material handling system, a check should be made to ensure that the valve controls are correctly interlocked with those of other units in the system.
- 4 Remove the guard covering the none drive end shaft and bearing.  
Check for correct rotation of the valve by reference to the direction of rotation arrow on the endplate.
- 5 With all guards securely fitted run the valve for 15 minutes.  
Isolate the power and check all retaining bolts for tightness.  
If these are satisfactory the valve is ready for production.

## **INITIAL MAINTENANCE**

### **ALWAYS ISOLATE AND LOCK-OFF THE ELECTRICAL POWER BEFORE ATTEMPTING ANY WORK ON THE VALVE**

After the first 50 hours of operation the following items should be checked and adjusted as necessary:-

- 1) Geared Motor:- Inspect the geared motor for lubricant leaks. If a leak occurs at the motor/gear interface it may be possible to stop it by tightening the flange bolts. If this does not stop the leak the geared motor should be removed from the valve and the relevant joint re-sealed using a commercial gasket compound.
- 2) Retaining Bolts:- Check all retaining bolts for tightness and adjust as necessary.

These procedures should be repeated after 3 months operation and thereafter every 6 months.

## **GENERAL MAINTENANCE**

Maintenance, apart from planned overhaul, should be adequately covered by regular and frequent attention to the gear motor lubrication and the non drive side bearing.

It is recommended that the complete Rotary Valve is dismantled for cleaning, inspection and overhaul as necessary at regular intervals.

The interval between such routine overhauls will vary with the product being handled and the operating time. To a large degree the rate of wear for a particular application would be assessed by practical experience.



## ROTOR BLADE RENEWAL

This procedure assumes the valve has been removed from production and is on a workshop bench. It is no possible to re-new the rotor blades whilst the valves are installed.

To re-new the rotor blades the following procedure should be adopted:-

- 1) Turn the rotor until one blade is vertical and all the retaining screws accessible.
- 2) Remove the blade retaining screws from this blade.
- 3) Remove the steel keep plate and the rubber blade from the rotor.
- 4) Turn the rotor until the next blade is accessible and remove the blades as above. If the rotor is difficult to turn by pulling each blade remove the cover from the back of the motor and spin the motor fan until the rotor turns to the required position.
- 5) Repeat for all six blades.
- 6) Clean the rotor and fit the one new blade and keep plate. Apply Loctite Thredlok or similar to each screw on assembly.
- 7) Check that the new rotor blade JUST touches the valve body bore and the endplates. When installed the rubber blade edges should bend slightly away from the body and endplates. If the rubber blade is too big trim it using a sanding wheel.
- 8) Replace all the rubber blades as described above. Check each blade as it is fitted to ensure that only a slight interference fit occurs with the valve bore and endplates. Trim individual blades as required.
- 9) When all blades have been replaced test run the valve for approximately 15 minutes and check the motor current. Compare this reading to the rated current shown on the motor plate. If the actual current drawn by the motor is high or the valve surfaces hot the rotor blades are too tight and require trimming.
- 10) If the valve is running cool and the motor current reading within the norm the valve is ready to be returned for use.

## **FAULT FINDING CHECKS**

### **1 Rotary Valve motor fails to start**

#### **Check**

- a Electrical supply (phase and voltage)
- b All isolators, fuses, overloads and re-set switches
- c Is motor burnt out. Check motor windings of motor
- c Is gear unit seized
- d Valve has not jammed

### **2 Rotary Valve motor functions but valve fails to deliver material**

#### **Check**

- a Material is being fed into valve
- b Blockages are occurring inside equipment upstream of the valve.
- c None drive end of the rotor shaft is rotating - this indicates that rotor shaft is not broken.

### **3 Rotary Valve produces excessive noise**

#### **Check**

- a Foreign bodies inside valve
- b Bearings worn or in need of lubrication
- c Gear box malfunctioning
- d Bearings malfunctioning

### **4 Rotary Valve produces excessive vibration**

#### **Check**

- b Faulty components ie rotor blade broken away from main rotor.
- c Material build up in valve.
- d Worn bearings

### **5 Bearing failure**

#### **Check**

- a Seal failure allowing material into bearings
- b Lubrication not carried out frequently
- c Securing bolts

## **FABRICATED ROTARY VALVES**

### **RECOMMENDED SPARES**

1 off            None drive side bearing

1 set            (6 Blades) Rubber rotor blades c/w retaining screws.

### **OPTIONAL SPARES**

1 off            Worm Geared Motor Unit