

Operating and Maintenance Instructions

RS ROTARY VALVES

Britton Procol Valves

4 The Green Old Dalby Leicestershire LE14 3LL
Tel: +44 (0) 1664 822 611 Fax: +44 (0) 1664 822 665

GENERAL

Britton Procol Rotary Valves are designed to control the flow of dry free flowing powders and granules in solids handling systems operating under gravity, pressure or vacuum conditions.

The valves are precision machined with close manufacturing tolerances and are supplied for use in a particular application. The valve should not be used for other applications without reference to our technical department.

Always refer to the valve serial number if further information or spare parts are required.

RESIDUAL HAZARDS

Rotary Valves are for use in fully enclosed systems with feed and discharge equipment connected to the valve inlet and outlet ports to prevent access to the moving rotor. The valve must not be used if either port remains uncovered.

Wear in the shaft seals can allow material to leak along the shaft.

Product may be retained within the valve when the rotor or endplates are removed. Provision must be made for safely removing this product.

NOISE

Under normal circumstances the valve generates little noise. If the valve becomes noisy it indicates product build up, mechanical failure or trapped particles within the valve.

OPERATION & COMMISSIONING

The rotor speed is factory set to suit the required feed rate. The drive chain sprockets must be changed if a different rotor speed is required.

If the valve does not deliver the specified feed rate the following causes should be investigated:-

- a) Rotor pockets not filling. Usually caused by product hang up above the valve due to increased pressure differential, excessive product aeration gas flow, worn rotor blade tips or poorly designed hopper outlets.
- b) Rotor pockets do not empty. This may be caused by moist product or an inherently "sticky" product.
- c) Loss of rotor speed.

Excessive noise is usually caused by:-

- a) Product build up in the valve bore.
- b) Product trapped between the rotor end disc and the body endplate or around the rotor vanes.
- c) Bearing or other mechanical failure.

STANDARD SPECIFICATION RS ROTARY VALVE

Rotary Valves are designed to metric standards and all fasteners or threads are metric.

Body Cast iron, stainless steel or aluminium alloy precision machined. Supplied with connecting flanges drilled to Procol square or round pattern.

Endplates Cast iron, stainless steel or aluminium alloy precision machined and spigot located within the valve body to ensure concentricity.

Rotor Type R1: Fabricated 8 blade open rotor with fixed blades machined to give a close clearance with the valve body.

OR

Type R4: Fabricated 8 blade closed end rotor with adjustable stainless steel blade tips machined to give a close clearance with the valve body.

OR

Type R6: Fabricated 8 blade open rotor with flexible blades cut to give a close clearance with the valve body.

Bearings Sealed ball bearings in cast iron housings outriggered from the endplates.

Shaft Seals Acrylic/PTFE packing gland shaft seals with adjustable followers.

Drive Coaxial geared motor TEFC IP55 suitable for 415-3-50 supply. The geared motor will be side mounted from the valve body on a mild steel baseplate with provision for drive chain adjustment.

Final Drive By fully guarded chain drive with Taperlock sprockets.

Paint Finish Procol Sapphire Blue air drying gloss paint BS 4800 20D45.

OR

Special paint finish specified by customer.

All valves are Works tested before despatch and are ready for installation. The valves should be stored in a clean, dry environment

If the Rotary Valve is to be stored, it is important that machined surfaces and shafts are coated with rust inhibitor to prevent the formation of rust.

PARTS IDENTIFICATION RA, RS & RV ROTARY VALVES

DATA SHEET: RS.01.05.03.B

Item No	Description
101	Body
102	End Plate
103	Bearing Cover
104	Ball Bearing
105	Bolt
106	Washer
107	Rotor
108	Lock Washer
109	Lock Nut
110	Key
111	Gland Follower
112	Packing Gland
113	Stud
114	Nut
115	Washer
116	Snap Ring
117	Screw
118	Washer
119	Lantern Ring
120	Coupling
121	Blade Tip
122	Dome Head Screw
123	Washer

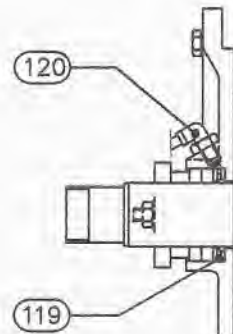
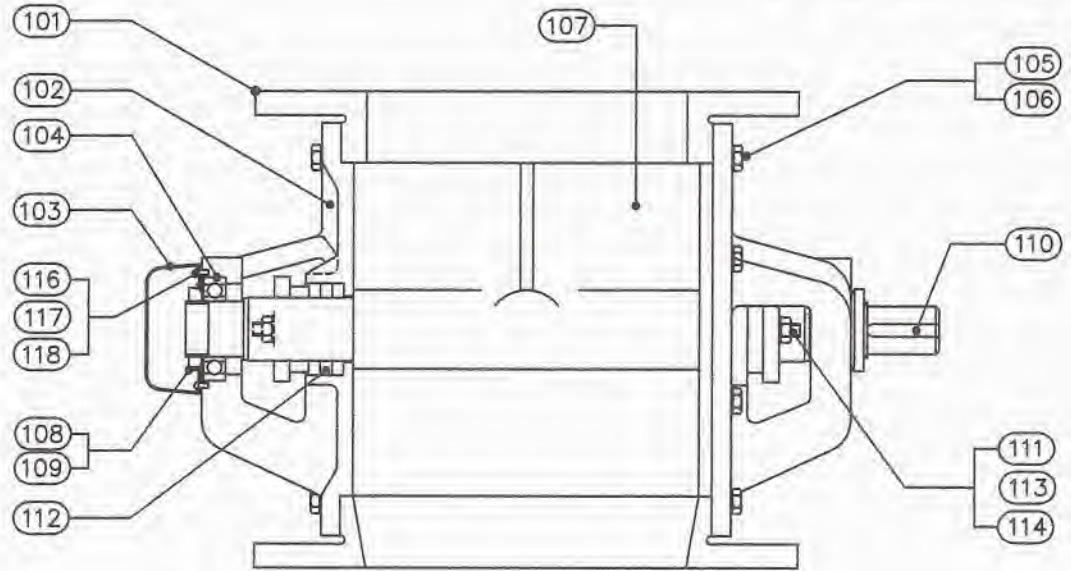

ALTERNATIVE
Air purge

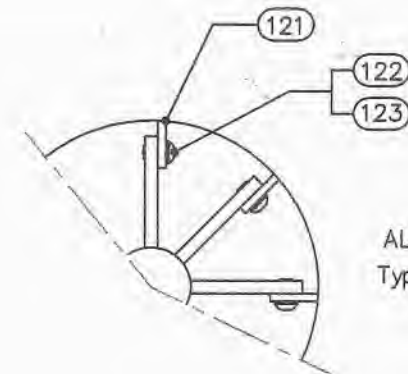

ALTERNATIVE
Type R4 Rotor

Britton Procol
VALVES

HEAD OFFICE: Kynochs Industrial Estate Bideford Devon EX39 4DT England Tel: +44 (0) 1237 421 465 Fax: +44 (0) 1237 421 459
 SALES OFFICE: 10 Purbeck Drive West Bridgford Nottingham NG2 7UA England Tel: +44 (0) 1158 469 469 Fax: +44 (0) 1158 461 834

THE DOWSON GROUP
BRITTON PROCOL VALVES

DOWSON HANDLING

HELI-TEC

www.dowsongroup.com

WRIGHTS

2

GENERAL HEALTH & SAFETY

Only qualified or approved personnel should undertake the installation, commissioning and maintenance of Procol Rotary Valves.

Health and Safety aspects cannot be over emphasized. The following notes highlight the major precautionary steps, which must be adhered to.

In the interest of Health and Safety at Work it is essential that, before installation, all aspects relating to installation, mounting position, support and all other related matters should be thoroughly investigated. Technical details relating to this equipment are either shown in the relevant leaflets or are freely available on demand from our technical department. If further advice is required, do not hesitate to contact us.

CHECK LIST BEFORE RUNNING

- 1) Fully observe all operating and safety instructions supplied with the Rotary Valve and geared motor.
- 2) Ensure that the valve is correctly guarded to comply with all local Health and Safety Regulations to ensure it is impossible to insert fingers, hands or any body part into the valve. A guide to guarding Procol Rotary Valves is included in the next section of these notes.
- 3) Do not operate the valve without the body vent ports plugged or connected to a suitable venting system. Do not remove these plugs from the valve and insert fingers - they will be amputated.
- 4) Isolate and lock-off all the electrical power supply to the geared motor before attempting any maintenance or other work on the valve.
- 5) Only competent persons must be allowed to install and maintain the valve
- 6) Ensure that Health and Safety instructions are made known to all personnel liable to be at risk. This is the responsibility of the Purchaser / User of the valve.

ROTARY VALVE GUARDING

Rotary Valves designed and manufactured by Britton Procol Valves are guarded to prevent access to all external rotating components. However the inlet and outlet of the valves must be guarded in situ to prevent anyone inserting fingers, hands etc into the rotating valve. This guarding cannot be incorporated into the valve assembly and is not supplied by Britton Procol Valves. It must therefore be supplied by the installation contractor and fitted as separate guarding during plant assembly.

Normally on a closed system equipment to which the Rotary Valve is attached will form an adequate guard to prevent access to the rotating rotor.

This may be the incoming and outgoing chutes or the feed hopper and adjacent take away equipment ie screw conveyor.

Where the Rotary Valve is the final piece of equipment and there are no chutes preventing access to the rotor a mesh guard fitted to the exposed access is mandatory in order to comply with Health and Safety legislation. The mesh must be small enough to prevent insertion of fingers into the valve and must be securely attached to the valve flange to prevent easy removal. Britton Procol Valves recommend an interlock switch should be incorporated into the guard design to prevent operation of the valve if the guard is removed.

All Britton Procol Rotary Valves have a vent port in the side of the body. This port is fitted with a threaded plug which should only be removed when the valve is isolated from the electrical supply and the vent port is piped to a venting system. **DO NOT REMOVE THIS PLUG** and insert a finger, stick, metal bar etc. Permanent damage will be caused to the valve and a finger **WILL BE AMPUTATED**.

Data Sheet RV.30.11.03.A. shows typical applications, which require guards fitting to the inlet and outlet of Rotary Valves. They do not form, nor should they be seen as, a comprehensive guide to guarding Rotary Valves and each application must be considered separately. Our technical department may be consulted for further advice if required.

FINGERS AND HANDS WILL BE AMPUTATED IF THEY ARE INSERTED INTO A ROTATING VALVE.

INLET AND OUTLET GUARDING IS MANDATORY.

Enclosed Feed Hopper

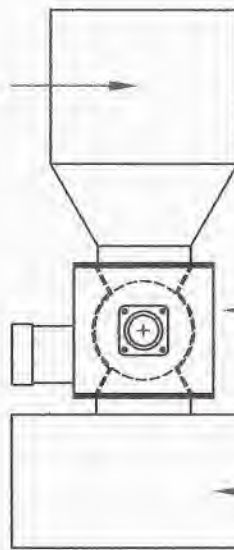

Rotary Valve Inlet & Outlet Fully Guarded By Adjacent Equipment

Enclosed Process Equipment

Enclosed System: – Inlet & Outlet Fully Guarded By Adjacent Equipment

Open Top Feed Hopper Must Be Fitted With Mesh Guard Inside Hopper

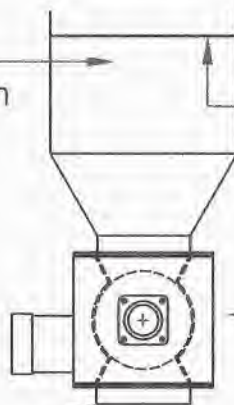

Mesh Guard

Rotary Valve Inlet & Outlet Must Be Fully Guarded By Installation Contractor

Mesh Guard Over Valve Outlet

Open System: – Inlet & Outlet Not Guarded By Adjacent Equipment
ADDITIONAL GUARDS MUST BE FITTED

Britton Procol
VALVES

HEAD OFFICE: Kynochs Industrial Estate Bideford Devon EX39 4DT England Tel: +44 (0) 1237 477 465 Fax: +44 (0) 1237 421 459
SALES OFFICE: 10 Purbeck Drive West Bridgford Nottingham NG2 7UA England Tel: +44 (0) 1158 469 469 Fax: +44 (0) 1158 461 834

THE DOWSON GROUP

www.dowsongroup.com

BRITTON PROCOL VALVES

DOWSON HANDLING

HELI-TEC

WRIGHTS

HANDLING

RS Rotary Valves are normally delivered shrink wrapped onto a pallet and should remain in this packaging until ready for installation. They may be moved in this condition by suitable equipment ie forklift, pallet truck etc.

After the valve has been removed from the pallet it may be lifted by using eyebolts through the flange holes or slings through the bearing housings. Do not lift by slings around the rotor shaft, geared motor or guards.

grade of oil or grease as stated in the manufacturers instructions.

Connect the motor to a suitable electrical supply as shown on the motor plate. Check that the valve rotates in the direction shown by the arrow on the chainguard. Before running the valve the approach equipment should be thoroughly cleaned and free from foreign matter. Serious damage will be caused to the Rotary Valve by weld spatter, nuts, bolts etc if they are allowed to enter it.

Valve Size	Weight In Kg			
	With Drive	Bare Shaft	Rotor	End Cover
125	62	47	9	9
150	73	58	12	11
200	102	87	15	16
250	152	128	28	28
300	200	176	35	34
350	348	325	43	40
400	387	342	55	68
500	546	495	98	110
600	862	770	220	190

INSTALLATION

Check the valve for external damage and remove foreign bodies from inside the valve. Install the valve with the inlet flange uppermost ie the geared motor will be on the right hand side when viewed on the chain guard and chainguard decals will be the right way up.

The valve flanges are supplied flat and it is important, in order to prevent distortion or stress within the valve body, that the mating flanges are also flat and level.

A soft gasket or mastic should be inserted between the valve and the mating flange. This will ensure a dust and weather-tight seal and will help to prevent valve body distortion.

Tighten the fixing bolts evenly and check that the rotor rotates freely.

Valve bodies are supplied with venting ports fitted with plugs. The ports must be connected to a suitable venting system (preferably a suction system) or remain plugged. Do not operate the valve with these vent ports open.

If fitted to the valve connect air purge ports to a clean dry air supply regulated to a pressure 0.33barg (5psi) above the maximum pressure within the valve.

Most geared motors are supplied grease packed or oil filled and do not require lubrication, however every unit must be checked and filled with the appropriate

ATEX Regulations

Where Rotary Valves are installed in potentially explosive atmospheres they will be certified for use in Zone 21 or Zone 22 areas. The installer must ensure that the valves are adequately earthed to prevent static discharges caused by non-conductive media.

START-UP PROCEDURE

Check the following:

- 1) All safety equipment, i.e. guards, cutout flaps and inspection flaps and lids are closed, that the valve is empty.
- 2) Where the valve is part of a material handling system, a check should be made to ensure that the valve controls are correctly interlocked with those of other units in the system.
- 3) Check for correct rotation of the valve by reference to the direction of rotation arrow on the chainguard.
- 4) With all guards securely fitted run the valve for 45 minutes to bed-in the packing gland shaft seals. Lightly tighten the seal follower adjusting nuts.
- 5) Isolate the power and check all retaining bolts for tightness.

If the above are satisfactory the valve is ready to use.

INITIAL MAINTENANCE

BEFORE WORKING ON THE VALVE ISOLATE AND LOCK-OFF THE ELECTRIC SUPPLY

After the first 100 hours of operation the following should be checked and adjusted as necessary: -

- 1) Packing Gland Shaft Seals: Inspect for signs of product leakage. Tighten the follower as required.
- 2) Drive Chain: Remove the chain guard cover and check the chain tension, the Taperlock Bush retaining screws in the drive sprockets and the chain alignment. Adjust as necessary.
- 3) Geared Motor: Inspect the geared motor for lubricant leaks. If a leak occurs at the motor/gear interface it may be possible to stop it by tightening the flange bolts. If this does not stop the leak the geared motor should be removed from the valve and the relevant joint re-sealed using a commercial gasket compound.
- 4) Retaining Bolts: Check all retaining bolts for tightness and adjust as necessary.

GENERAL MAINTENANCE

Maintenance, apart from planned overhaul, should be adequately covered by regular and frequent attention to the rotor shaft glands, reduction gear lubrication and adjustment and lubrication of the motor drive chain and sprockets.

It is recommended that the complete Rotary Valve be dismantled for cleaning, inspection and overhaul as necessary at regular intervals.

The interval between such routine overhauls will vary with the product being handled and the operating time. To a large degree the rate of wear for a particular application would be assessed by practical experience.

Shaft Seals

Check and adjust the shaft seals every month or more frequently if leakage from the seals occurs between inspections. Adjust the shaft seals with the power off taking care to pull up the gland follower evenly. Do not over tighten. If normal running adjustment is insufficient to prevent product leakage, or gives rise to continual localised overheating, the gland packing should be completely renewed.

The importance of gland maintenance cannot be overstressed, since a leak proof gland prevents escapes of dust particles and consequently wear due to erosion is largely eliminated.

Drive Sprockets and Chain

Check and adjust the chain drive tension every month. Adjustment to vary the chain tension is provided in the motor mounting arrangement where nuts can be adjusted on studs to jack the geared motor in or out.

Before replacing the chain examine the sprocket teeth for signs of wear and renew if necessary.

When replacing the sprockets and drive chain ensure the sprockets are correctly aligned and that the chain tension is correct. The chain is correctly tensioned when with one straight length of chain reasonably taut it is possible to manually flex the trailing length by 12 - 15mm.

Bearings

Standard bearings are grease packed, sealed for life and maintenance free. They should be checked every 3 months and replaced as required.

Geared Motors

Maintain the geared motor as described in the manufacturers instructions.

Air Purge

Check that the air purge lantern ring passages are not blocked by product.

ROTOR REMOVAL

This procedure assumes the valve has been removed from production and is on a workshop bench. It is possible to remove the rotor of small valves whilst they are installed but because of the weight of the rotor we do not recommend this for valves larger than the 250mm size.

To remove the rotor from the valve body the following procedure should be adopted:-

- 1) Remove the chain guard cover, the drive chain and both sprockets.
- 2) Remove the guard back plate.
- 3) Bend the lock washer tab away from the slot in the lock nut on the rotor shaft.
- 4) Remove the lock nut and washer from the shaft. When removing the nut use either a soft drift or the correct size "C" spanner.
- 5) Remove the none drive shaft cover (yellow cover).
- 6) Remove all the retaining screws from the none drive endplate.
Insert 2 of these screws into the tapped jacking holes in the endplate.
Tighten the screws and remove the endplate and rotor assembly from the valve body.
- 7) Remove the lock nut and washer from the none drive side of the shaft.
- 8) Drift or press the rotor shaft out of the bearing and remove the rotor from the endplate assembly.

When the valve is being rebuilt, the lock nuts and washers should be loose until the end clearances between the rotor blades and the endplates have been set. To adjust the end clearances the following method should be used:-

- a) With the lock nuts away from the bearings push (or tap) the rotor against the none drive endplate. Use feeler gauges to measure the gap between the rotor blade ends and the drive endplate.
- b) Hand tighten the lock nuts until they just touch each the bearing.
- c) Tighten the lock nuts on both sides until the clearance at each end of the rotor blades is equal ie half the distance measured in step (a).
- d) When the rotor is centrally positioned between the endplates tighten the lock nuts and bend over the lock washers tabs into one of the slots in the lock nuts.

BLADE TIP ADJUSTMENT

Blade tip adjustment is possible on valves fitted with tipped rotors. However if wear has taken place in the valve it normally occurs randomly on both the rotor and the valve body. In most instances it is not possible to close the tip clearances unless the valve body is re-machined.

It is possible to adjust rotor blade tips with the valve in-situ if access to the inlet or outlet of the valve is possible. However in order to re-set the tip clearances the internals of the valve must be clean and free from product residue. It is therefore strongly recommended that the valve should be removed from production, the rotor removed and the valve thoroughly cleaned before starting to adjust the tips.

The valves are normally manufactured with tip clearances of 0.006" – 0.008" (0.15mm – 0.2mm) To re-set this clearance feeler gauges of the correct thickness are required. To adjust rotor blade tips the following procedure should be adopted: -

1) ISOLATE ALL POWER SUPPLIES BEFORE WORKING ON THE VALVE.

- 2) Turn the rotor until one blade is vertical and all the tip retaining screws accessible.
If the rotor is difficult to turn by pulling each blade remove the cover from the back of the motor and spin the motor fan until the rotor turns to the required position.
- 3) Loosen all retaining screws until the tip can just be moved.
- 4) Turn the rotor until the blade is just within the body bore i.e the blade is to the side of the inlet / outlet and the retaining screw head is accessible.
- 5) Place a 0.006" feeler gauge at the ends of the tip. Move the tip so the feeler gauge is nipped between the tip and the valve bore. Tighten the tip retaining screws.
- 6) Check that the clearance is consistent along the full length of the tip. If necessary re-adjust the tip until the clearance is correct
- 7 Turn the rotor until the next blade tip is accessible and adjust the tip as described above.
- 8) When all blade tips have been adjusted test run the valve for approximately 15 minutes and check that the rotor runs freely. There should be no sound of tip scraping or occasional catching when the rotor turns. If this occurs check each individual tip as in (6) above and re-adjust where required.

ROTOR BLADE REPLACEMENT

General

Blade replacement is possible on valves fitted with flexible rubber or replaceable steel blades.

It is not possible to fit new rotor blades with the rotor assembled within the valve

The rotor should be removed (see separate instructions) and the valve thoroughly cleaned before fitting new blades.

Flexible Blades

Replacement flexible blades are usually supplied cut to size and with holes to suit the drilled vane and keep plates. Provided the valve body is not badly worn, the valve will be "as new" once the replacement blades are installed.

Steel Blades

Fitting new steel blades will not necessarily restore the original rotor tip clearances.

If wear has taken place in the valve it usually occurs randomly on both the rotor and the valve body. In order to regain correct tip clearances the valve body and the rotor (with new blades) should be re-machined. All new steel blade sets are supplied oversize to allow for this re-machining.

New Blade Fitting

The following procedure should be adopted: -

1) TURN OFF AND ISOLATE ALL POWER SUPPLIES TO THE VALVE BEFORE BEGINNING MAINTENANCE WORK ON THE VALVE.

2) Remove the valve rotor (see separate instruction sheet).

3) Select one blade assembly and remove all blade retaining screws. Remove the loose keep plate. Repeat for all other blades.

4) Clean the rotor blades and keep plates.

5) Place one new blade onto the fixed rotor vane and place the keep plate over the new blade so that all holes align.

6) Apply a bead of Loctite "Thread Loc" or similar to the retaining screws and fit them through the holes in the keep plate and blade. Tighten the screws into the tapped holes in the rotor vane. Use an Allen key and fully tighten all retaining screws.

7) Repeat steps 5 and 6 for all remaining blades.

8) Re-fit the rotor into the valve (see separate instruction sheet) and run the valve to ensure correct fitting.

FAULT FINDING CHECKS

1 Rotary Valve motor fails to start

Check

- a Electrical supply (phase and voltage)
- b All isolators, fuses, overloads and re-set switches
- c Is motor burnt out. Check motor windings of motor
- c Is gear unit seized
- d Valve has not jammed

2 Rotary Valve motor functions but valve fails to deliver material

Check

- a Material is being fed into valve
- b Blockages are occurring inside equipment upstream of the valve.
- c None drive end of the rotor shaft is rotating - this indicates that rotor shaft is not broken.

3 Rotary Valve produces excessive noise

Check

- a Foreign bodies inside valve
- b Bearings worn or in need of lubrication
- c Gear box malfunctioning
- d Bearings malfunctioning

4 Rotary Valve produces excessive vibration

Check

- b Faulty components ie rotor blade broken away from main rotor.
- c Material build up in valve.
- d Worn bearings

5 Bearing failure

Check

- a Seal failure allowing material into bearings

VALVE SPARES

a) RECOMMENDED SPARES

- 1 off Set (6 coils) Gland Packing
- 2 off Lock Nuts
- 2 off Lock Washers
- 2 off Bearings

b) OPTIONAL SPARES

- 1 off Geared Motor
- 1 off Chaindrive Complete
- 1 off Set of Rotor Tips (R4 Rotor Only)
- 1 off Set of Rotor Blades (R6 Rotors Only)

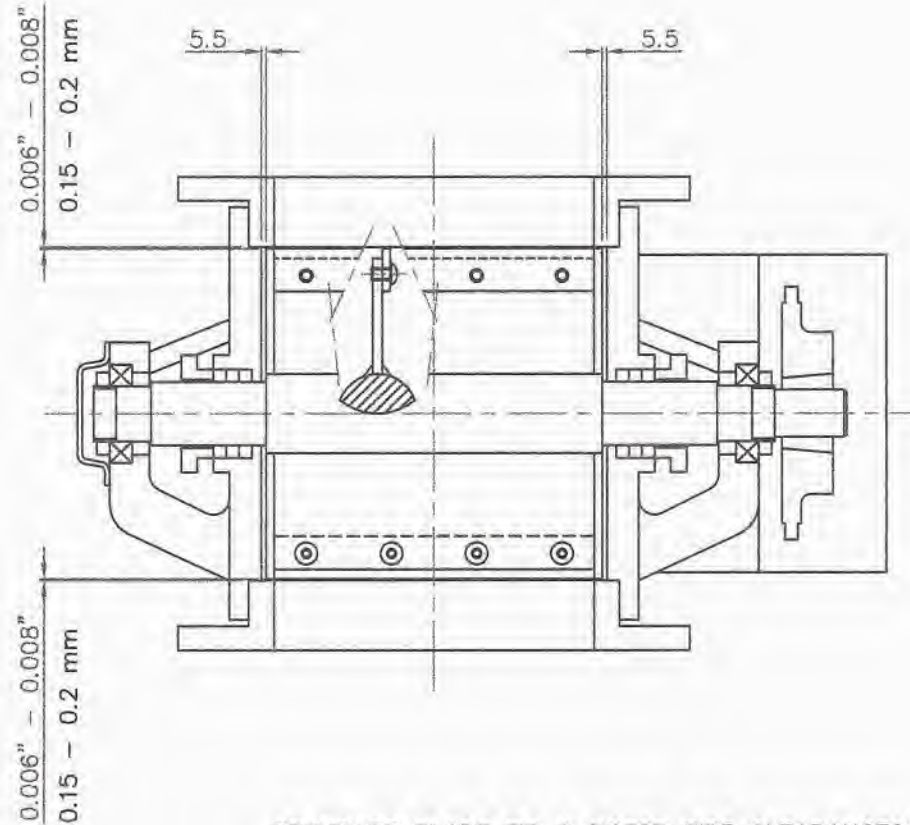

STANDARD BLADE TIP & ROTOR SIDE CLEARANCES

Britton Procol
VALVES

HEAD OFFICE: Kynochs Industrial Estate Bideford Devon EX39 4DT England Tel: +44 (0) 1237 421 465 Fax: +44 (0) 1237 421 459
SALES OFFICE: 10 Purbeck Drive West Bridgford Nottingham NG2 7UA England Tel: +44 (0) 1158 469 469 Fax: +44 (0) 1158 461 834

THE DOWSON GROUP
BRITTON PROCOL VALVES

DOWSON HANDLING

HELI-TEC

www.dowsongroup.com

WRIGHTS